

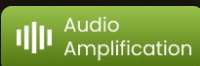

NAC-2320

Wall Speaker

The NAC-2320 is an indoor wall-mounted speaker with clear and pleasant sound quality. It is easy to install and suitable for public areas or meeting rooms.



SPECIFICATION

Frequency Response	200-16KHz
Sensitivity	89dB±3dB(1m/1w)
Rated Power	5W/10W
Line input	100V
Rated Impedance	100V: 2000Ω±10%_5W 100V: 1000Ω±10%_10W
Coverage Angle	150° (H) × 150° (V)
Material	HIPS
Grill	Iron Grill
Component	4.5"*1
Finished Colour	White
Mounting Hole Size	M4 Self-tapping Screw
Weight	0.87kg
Dimension(mm)	202*150*100
Operatiing Temperature	-25°C~+55°C
Warranty	2 Years

CIRCUIT DIAGRAM



Applicable Cable:

- 600V vinyl-insulated cable (IV wire or HIV wire) Solid copper wire: $\Phi 0.8\text{--}\Phi 1.2$ mm
- 7-strand twisted copper wire: 0.75–1.25 mm

INSTALLATION

unit: mm

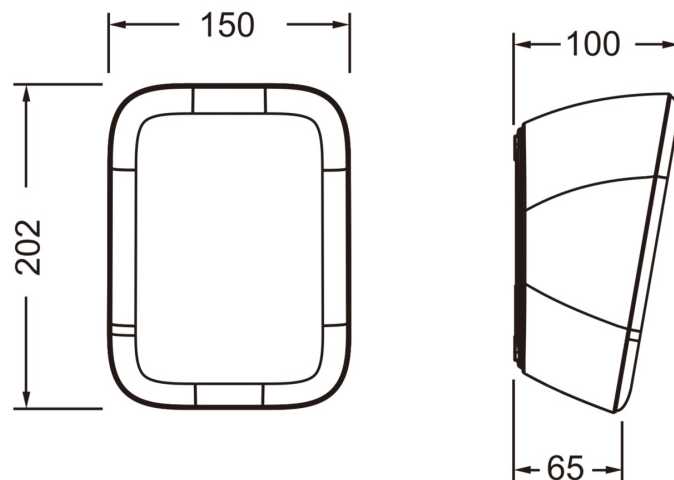

Measured curve

SPL vs Freq - 1W/1m Normalized

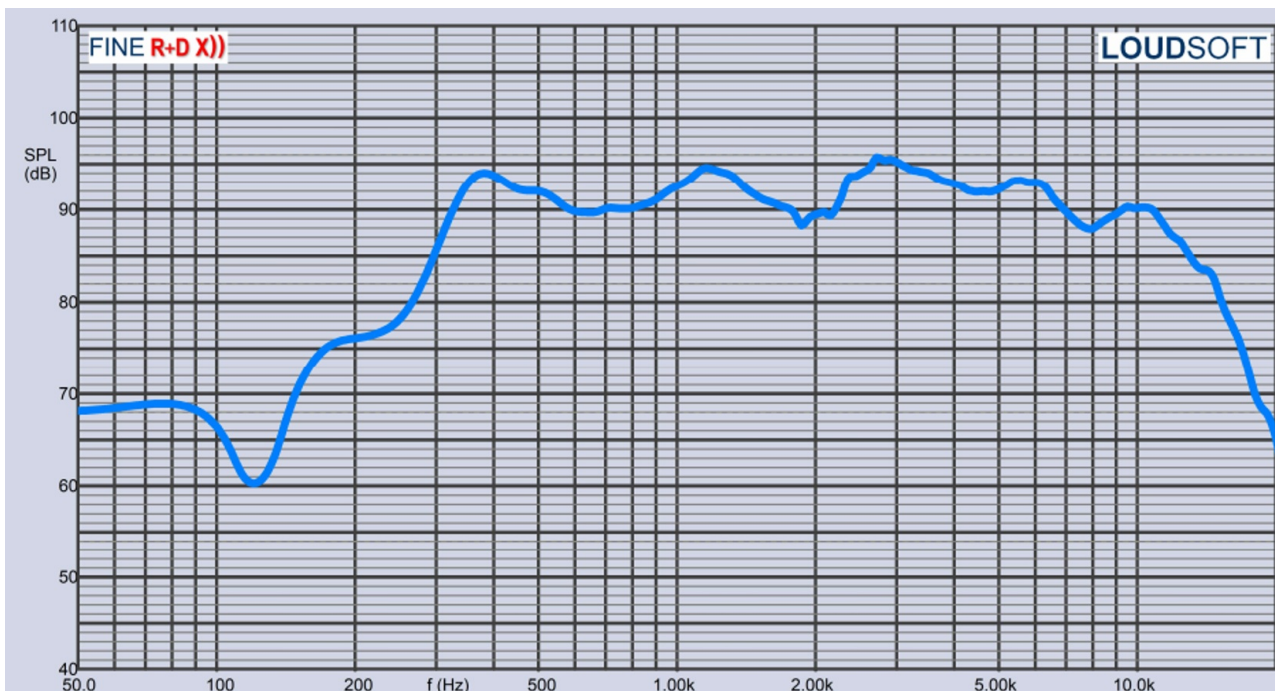

Coverage Angle, 1/3 Octave

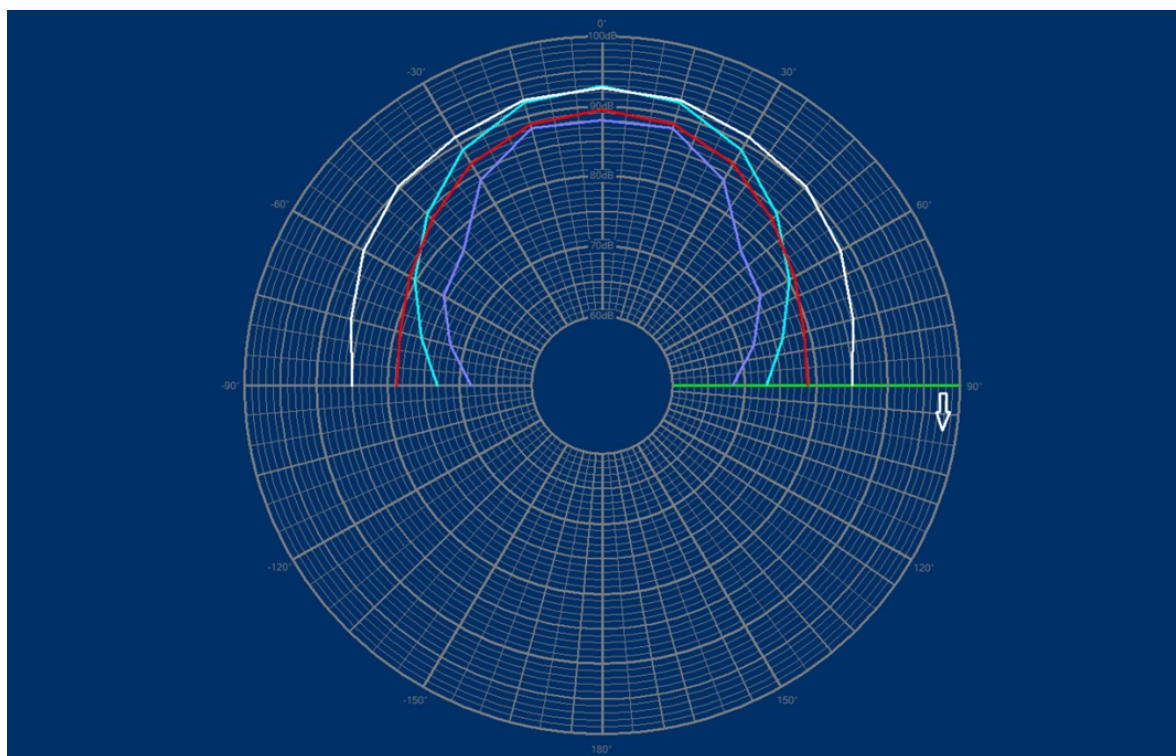

SPON SPON Communications Co., LTD

Address: No.70, Nantang Road, High-Tech Zone, Changsha, China.

Mobile: +86 138 7314 3517

Email: inquiry@sponcomm.com

Tel: +86 731 8557 0190



www.sponcomm.com